

Base Transceiver Station (BTS) Safety and Fault Management

Chetan Patil, Channabasappa Baligar

Abstract— In mobile communication the Base Transceiver Station (BTS) site and the tower maintenance play an important role. In the present day scenario some problems are being faced in its maintenance. The major problems faced include the theft of wires, the fluctuation of temperatures, unauthenticated entry, fuel amount being unnoticed and the vendor and the technician's time management in case of any of the stated problems. In the project work BTS safety and fault management system the measures are taken to rectify these problems. The method makes use of GSM modem which gives the instant message about the each activity happening in the site. The temperature sensors will sense the temperature of the room and if it rises above the threshold value the GSM module will send the message to the master mobile which is already set in the system. The cell site Base Transceiver Station (BTS) which are operated by Diesel generator can be controlled manually or can be put in automatic mode. In addition the site is under the surveillance of CCTV camera which turns ON automatically whenever the site door is opened as a safety measure. Door open/close controller is used for the automatic door opening and closing. The site door can be accessed only through the RFID authentication system. The situation in the site is updated to the technician through messages.

The method can greatly improve the BTS site operating efficiency, reduces the delay and fuel consumption. The project has better performance and involves less hardware complexity. The project gives a single comprehensive solution that remotely controls and monitors the subsystems inside each base station site and enables network operators to coordinate and manage the conditions at all base station sites across their network. This system does not demand any changes in the existing infrastructure but just adds more features to it.

Index Terms— Automation, ARM, BTS, Mobile tower, Authentication.

I. INTRODUCTION

Cellular towers form the backbone of our modern communications infrastructure. Each tower is incorporated with a power plant with batteries, diesel generator, tank for backup power, air-conditioning and power conditioning unit. Some sites are not supported by utility power hence sometimes they rely on hybrid power sources like solar power plants. The sensors that monitor temperature, diesel fuel levels, site door open/close status [1]. This project aims a single comprehensive solution that remotely controls and monitors the subsystems inside each base station site and enables network operators to coordinate and manage the conditions at all base station sites across their network. Time management of cell sites in case of any failure protects the cell network, tracks and measures cell site performance for peak operation.

Manuscript received December, 2013.

Mr. Chetan Patil, Department of VLSI design and Embedded systems, VTU Extension center UTL technologies, Bangalore, India.

Prof. Channabasappa Baligar, Department of VLSI design and Embedded systems, VTU Extension center UTL technologies, Bangalore, India.

On-demand Intervention in Site failures or breakdowns, since the best problems are those successfully avoided [1][2]. This project provides the Power management of which enables the wireless operators to monitor cell sites remotely for performance degradation before it affects network integrity.

II. PROJECT BACKGROUND

A. Aim of the Project

The aim of the project is to Control multiple individual subsystems per base station site and thousands or more base station sites across your network. Alerting users immediately when temperature rises to prevent or reduce damage to cell sites. Reducing energy consumption through automatic maintenance and monitoring of temperature. Detecting theft by monitoring and controlling remote cameras, door sensors. Dramatically reducing site visits and turns entire network a deeper shade of green.

B. Project problem statement

- Problems occur because of Theft of copper wires. As the copper weigh high and have high cost in market so getting into the burglar's eyes.
- Problems occur with the fluctuation of site temperature. The site machineries work at specific temperature, if temperature goes above some value then they may get permanent damage.
- Problems occur with the unauthenticated entry. Only site technicians and admin are authorized to enter in the cell site but with poor security any one can easily enter the cell site.
- Problem is Generator fuel amount being unnoticed. So if in case of power loss and if no fuel is present in generator then the whole system stop working.
- Problem with vendor and the technician's time management in case of any of the above problems. So there should be minimum delay to handle the problem.

C. Description of proposed solution

- **Wire Theft Management:** The site room is under the cover of CCTV camera. The site room includes door open/close sensor. Whenever any person enters the room the message is sent to the site admin and CCTV camera will turn ON.
- **Temperature Maintenance:** The system includes a temperature sensor within the Site. If the site temperature rises above the maximum allowed value, the system automatically opens the site door and sends this information message to technician
- **Authenticated entry management:** The system includes a RFID Reader at the door entry. This setup opens the door only if valid card is moved across the reader. All entry records like Time, person information etc are saved in the data base. While leaving the site the person has to move the card before RFID reader again to close the door.

- *Generator fuel level indication:* A fuel gauge indicator is provided in the generator fuel tank. When the fuel level goes below the set value a message is sent to the Technician requesting for refilling. All fuel filling records are saved in the database.

III. SYSTEM DESIGN

The design steps and working principles of the system is organized into two different units like Hardware unit and Software unit. Hardware unit includes micro-controller, power supply section, display section, sensor unit, and alarm. Software unit includes the compiler to build the assembly program used in ARM microcontroller.

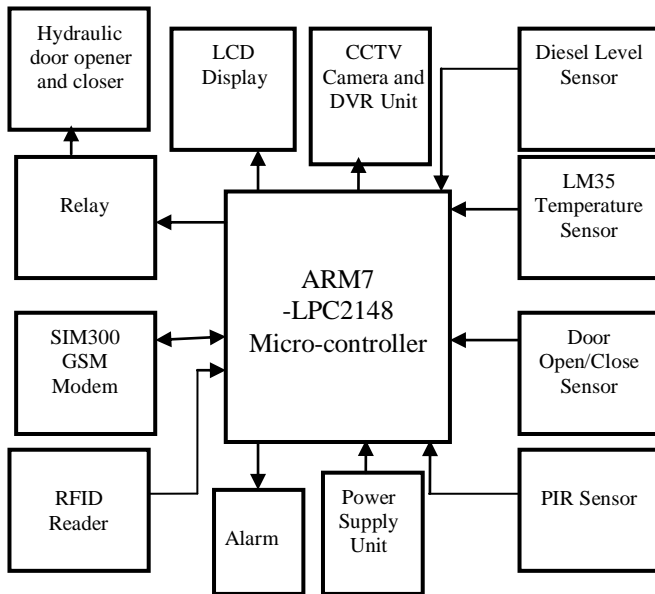

The whole site room is under the cover of CCTV camera. The site room includes door open/close sensor. Whenever any person enters the room the message is sent to the site admin and CCTV camera turns ON. The system includes a temperature sensor within the Site. If the site temperature rises above the maximum allowed value, the system automatically opens the site door and sends this information message to technician

As shown in the above figure, the system includes a RFID Reader at the door entry. This setup opens the door only if valid card is moved across the reader. All entry records like Time, person information etc is saved in the data base. While leaving the site the person has to move the card before RFID reader again to close the door. A fuel gauge indicator is provided in the generator fuel tank. When the fuel level goes below the set value a message is sent to the Technician requesting for refilling. All fuel filling record can be saved in the database.

Purpose of using each component are-

1. ARM7: To read the status from each component and to actuate the controlling devices.
2. Diesel level Sensor: To sense the level of diesel in the diesel tank, these power the BTS in case of main power cut.
3. LM35: Senses the BTS room temperature.
4. Door open/close sensor: This gives the status of door as whether it is closed or opened.
5. PIR Sensor: Detects the presence of humans inside the room.
6. CCTV Camera: Records the status of the room.

7. LCD Display: To display the temperature, Diesel level and other parameters of the BTS.
8. Hydraulic Door Opener and Closer: To open and close the door automatically.
9. Relay: To switch the AC or High voltage DC devices.
10. GSM modem: To send the message about BTS status.
11. RFID Reader: To allow only authenticated entry.

Component Description-

1. *LPC2148:* The LPC2148 microcontroller is based on a 32/16 bit ARM7TDMI-S CPU with real-time emulation and embedded trace support, that combines the microcontroller with embedded high speed flash memory ranging from 32kB to 512kB. A 128-bit wide memory interface and unique accelerator architecture enable 32-bit code execution at the maximum clock rate. [13]. As our system requires two UART ports, 11 IO pins and one ADC LPC2148 is suitable for this application.
2. *LM35:* Temperature Sensor: The LM35 series are precision integrated-circuit temperature sensors, whose output voltage is linearly proportional to the Celsius (Centigrade) temperature. The LM35 thus has an Advantage over linear temperature sensors calibrated in ° Kelvin, as the user is not required to subtract a large constant voltage from its output to obtain convenient Centigrade scaling [14]. The LM35 does not require any external calibration to provide typical accuracies of $\pm 1/4^{\circ}\text{C}$ at room temperature and $\pm 3/4^{\circ}\text{C}$ over a full -55 to $+150^{\circ}\text{C}$ temperature range [14].
3. *16x2 LCD Display:* LCD (Liquid Crystal Display) screen is an electronic display. These modules are preferred over seven segments and other multi segment LEDs. The reasons being: LCDs are economical; easily programmable; have no limitation of displaying special & even custom characters (unlike in seven segments), animations and so on. A 16x2 LCD means it can display 16 characters per line and there are 2 such lines. In this LCD each character is displayed in 5x7 pixel matrix. This LCD has two registers, namely, Command and Data. As our system incorporates ARM2148 Microcontroller board which operates on 5V DC supply, same can be used to power the LCD.
4. *SIM300 GSM Modem:* GSM (Global System for Mobile Communications) is the most popular standard for mobile telephony systems in the world. In this project we used GSM modem which has SIM300 Module. This is a plug and play GSM Modem with a simple to interface. We can use it to send SMS, make and receive calls, and do other GSM operations by controlling it through simple AT commands from LPC 2148 micro controller.
5. *RFID Reader:* Radio-frequency identification (RFID) is the wireless non-contact use of radio-frequency electromagnetic fields to transfer data, for the purposes of automatically identifying and tracking tags attached to objects. The tags contain electronically stored information typically incorporated into a product, animal, or person for the purpose of identification and tracking using radio waves. A typical RFID system is made up of three components: Tags, Readers, Host controller system.
6. *Door Open/Close Sensor:* It is Iron Door Magnetic Sensor MC-58. Monitoring the door switch state, output ALARM switch signal. The two magnets included in the sensor are placed a short distance apart. One of the

magnets is placed on the door, while the other is usually placed on the door frame. The magnets need to be spaced properly, in order to ensure that they have a magnetic connection. The sensor monitors the integrity of the connection between the two spaced magnets. If that connection is broken, the sensor is triggered, and a signal is sent back to the control panel, which is processed as an alert.

7. *Diesel Level Sensor:* Diesel level sensor consist of Magnetic switch / Read switch. It will not come to contact with Water i.e. Shock proof. Switch is made up as a free movement switch, when switch is free O/p will be Open NO. When the switch is in UP with Liquid - O/p will be Closed NC. It operates with V DC. It can be used to detect any Liquid level.
8. *PIR Sensor:* PIR sensor senses motion, almost always used to detect whether a human has moved in or out of the sensors range. PIRs are basically made of a Pyroelectric sensor, which can detect levels of infrared radiation. Everything emits some low level radiation, and the hotter something is, the more radiation is emitted. They are small, inexpensive, low-power, easy to use and don't wear out. They are often referred to as PIR, "Passive Infrared", and "Pyroelectric".

IV. DESIGN AND DEVELOPMENTS

First step is to initialize all the required variables ,once initialization is done next flow is to set the ADC channel AN0 from AN0 to AN3 as analog channels , next initialize LCD and display some data's on LCD to check the working of LCD. Initialization of UART for 9600 baud rate is the next step. Baud rate settings are done by using registers of UART. Next step is initialize send and receive message to GSM module.

Once initialization, displaying done, initialize the UART at 9600 baud rate to communicate with RFID and GSM modules. Then start waiting for any system GPIO state changes connected. If an RFID card is detected then read the card ID and compare with stored IDs. If valid card is shown then open the door by actuating the hydraulic door opener, send the entry details to the technician, turn on the CCTV camera and start displaying the current state of sensors. If the card ID is not valid then just send alert message to technician.

If the temperature is above the normal value then open the door and send alert message to technician and turn on video recording. If diesel level is low then send the message to the technician to inform him about the diesel level status, all these are described following flow chart.

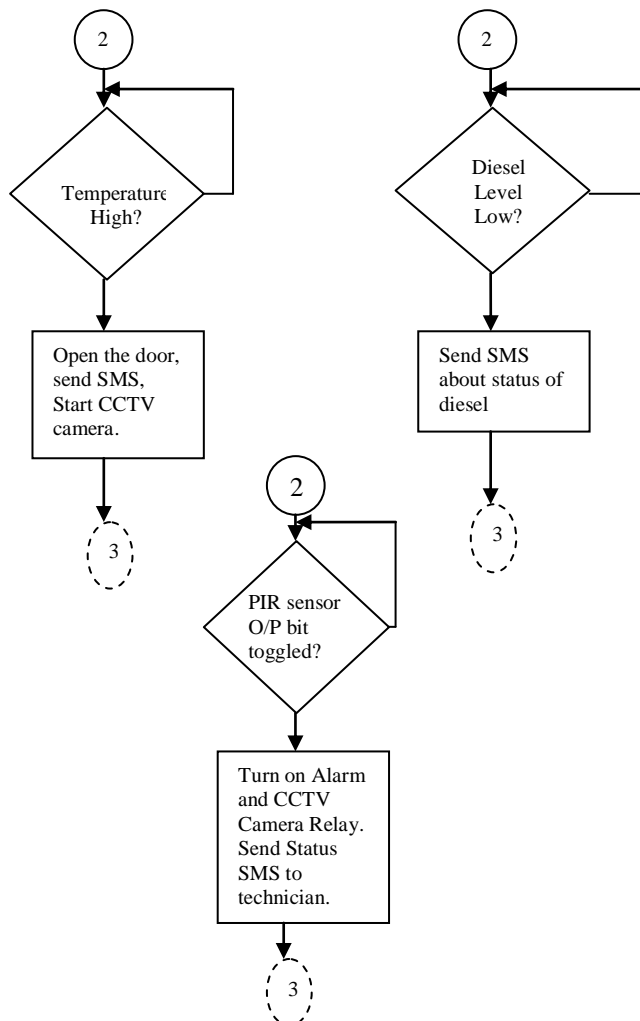
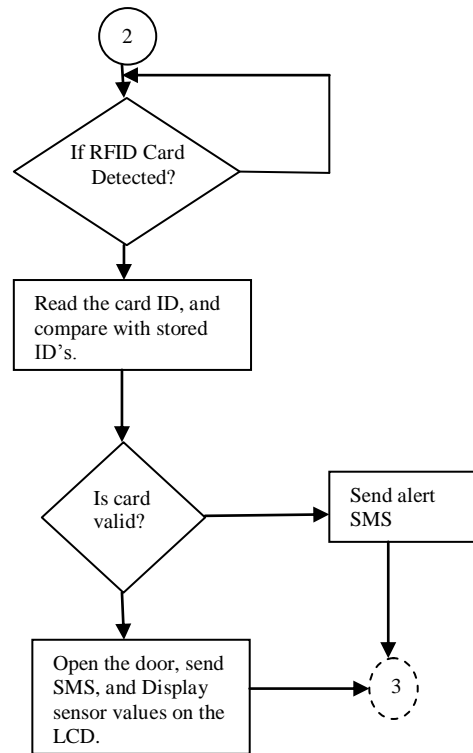
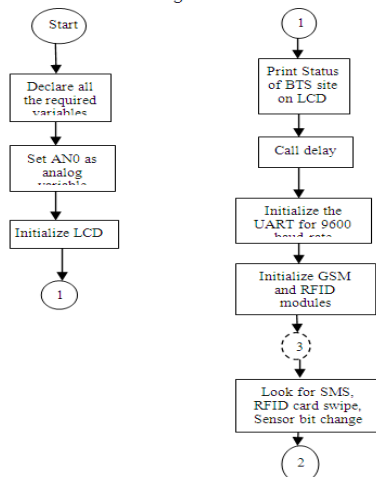

V. TESTING AND RESULTS

Testing is necessary to check whether device or module working properly or not. There are many methods for testing. Here we have followed two testing strategy, those are Unit testing and Integration testing

A. Unit testing

Unit testing includes testing individual hardware and software modules to ensure that they operate correctly. Each component is tested independently without other module; a test runs individual functions against known inputs, and the results verified against expected results.

In this project individual test done on every module, initially testing done on single channel then same is repeated for all other channels. Testing of all LCD, ADC, UART, GSM, and RFID also tested individually. By displaying some characters on LCD its function can be checked, similarly by terminal window UART function can be checked. In below figure testing of door open/close sensor and PIR sensor are shown.

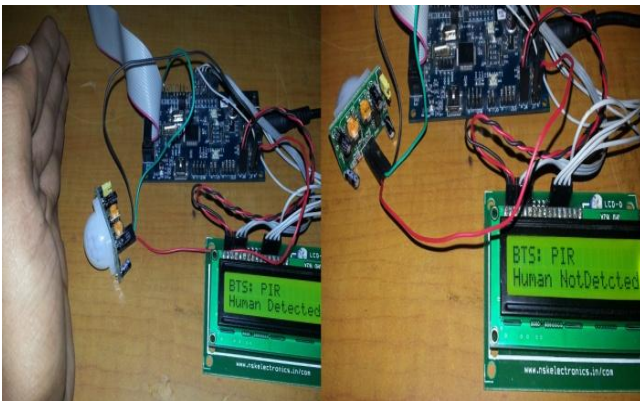

B. Testing

Once the individual software components have been tested, they must be integrated to create a partial or complete system. This integration process involves building the system and testing the resultant system for problems that arise from component interactions. Integration tests were developed from the system specification and integration testing begins as soon as usable versions of some of the software components are available.

In this project after integration work, all the modules are tested together which includes all software and hardware modules to check desired working result.

C. Results

Result part includes all the results that can be observed once project is ready; it contains both hardware part and software part. Working model of the system is shown in below figures. From the result observation it is cleared that all the modules are working as expected in objectives.



VI. CONCLUSION

In this project all the modules are working as expected and stated in objectives of project. This project introduced beneficial techniques to protect the BTS site and its proper uninterrupted operation like, BTS Security Monitoring enables users to monitor remotely the conditions of base transceiver stations (BTS). The core of the solution is the GSM SMS controller which always performance monitoring features. Great time management and hence required less number of technicians. This system does not demand any changes in the existing infrastructure to install it; it can be used as add-on to the existing system. With the help of this system the technician is alerted of any unexpected situation and can attend to it immediately and hence the loss is minimized.

A. Limitations

In this project mainly two limitations are observed. First one is, when the temperature falls below the 20°C, the door automatically opens; at this time there may be possibility of entry of thieves into the BTS room. And second one is, No possibility of entry into the site in case of emergency service if the person does not have the RFID card.

B. Future Enhancements

This project can further be extended to remotely located machinery systems. This project can also be suitable to extend the services which need maintenance like temperature, pressure etc.

ACKNOWLEDGMENT

A project work is a great enormity which cannot be accomplished by a single individual. Eventually I, Chetan Patil, grateful to a number of individuals whose encouragement and professional guidance made it a very pleasant endeavor. I am grateful to a long list of people who have helped me directly or indirectly, knowingly or unknowingly.

I express my deepest gratitude to, Principal and Head of Dept. Dr. V Venkateswarlu, VTU Extension Center, UTL Technologies Ltd., Bangalore for taking keen interest and for providing guidance and encouragement, which has helped me immensely, in completing the project work.

I express my profound gratitude to internal guide, Mr. Channabasappa Baligar, Professor, VTU Extension Center, UTL Technologies Ltd., Bangalore for his help in understanding the concepts and guidance, making this project successful. I sincerely thank him for valuable suggestions.

I extend my thanks and regards to external guide, Anil Patil, Project manager, E-Rachit Technologies Pvt. Ltd., Bangalore for his support and guidance.

I express my sincere thanks to entire faculty members of VTU Extension Centre, UTL Technologies Ltd, Bangalore who has encouraged me. Last but not the least; I would like to put in sincere thanks to my parents and friends who have helped directly or indirectly towards completion of this project.

REFERENCES

- [1] Pizzuti, Grossoni, Antonetti, "Power and Conditioning Telemanagement Integrated System," Twenty-Seventh International Telecommunications Conference, 2005. pp.83-88, Sept. 2005
- [2] Ajosh, K, Sujit P, Rajan A, Aravind V, Raveendranathan K.C., "A Smart BTS Power Management System," Computational Intelligence and Communication Networks (CICN), International Conference on 2010, pp.488-492, 26-28 Nov. 2010.
- [3] Satoshi Maruyama, Katsuhiko Tanahashi, Takehiko Higuchi (2002). Base Transceiver Station for W-CDMA System. August 8, 2002.
- [4] Yi xianjun and Liu luimei "Development of high precision temperature measurement system based on ARM" 9TH International conference an electronic measurement and instrument, pp 795-800, May 2009.
- [5] FANG Bo, QING Dawei (2007). The Burglar AlARM System of Power Table. Technology of Electrician. (4) 30-31.
- [6] ZHOU Binfa, LI Tao, LIN Tao (2005). Study on Anti-theft alARM system of Street lighting cable. Lighting monitoring . (4).23-24.
- [7] LIN Lisheng (2007), The circuit design of anti-theft alARM system for general power cable. Hydraulic engineering. (3).59.
- [8] WANG Jun (2003). The line laying of buried cable and an ideal anti-theft device. Engineering technology. (23).275-279.